



**Thompson and Democratic Caucus Chair Aguilar Host Student Town Hall**  
PAGE 6

**CDFW Releases Ocean Salmon Harvest Tracking Tools**  
PAGE 5



# Dixon Independent Voice

The Official Newspaper of Record for the City of Dixon

VOLUME 34 • ISSUE 23

Serving Dixon and Solano County since 1993

JUNE 5, 2026

**SEE INSIDE**

**SIXTY YEARS LATER HIS SCIENTIFIC DREAM CAME TRUE**



PAGE 10

**ANDERSON PTO NAMED NONPROFIT OF THE YEAR**



PAGE 3

**GLASSY-WINGED SHARPSHOOTER FOUND ON COSTCO PLANTS**



PAGE 9

## Kicking Off Summer



Downtown Dixon Business Association's (DDBA) will host the return of Railroad Days from 10 a.m. to 6 p.m. June 20 and 21 throughout downtown Dixon. Photo by Debra Dingman

By Kendall Brown

**DIXON, CA (MPG)** - Residents will have a variety of opportunities to shop, volunteer, learn and celebrate throughout June as local organizations, businesses and community groups host events across Dixon and neighboring communities.

Downtown Dixon Business Association's (DDBA) summer event season begins with the Downtown Dixon Weekly Farmer's Market, held every Wednesday from 5 to 7 p.m. through Oct. 28. Hosted at Pardi Plaza, 132 E. A St, the event,



Atkinson Self Storage will host a document shredding event from 10 a.m. to 1 p.m. June 13 at its facility, 1800 N. First St. The service costs \$10 per banker-sized box of papers and documents. Both cash and card payments will be accepted. Photo by Kendall Brown

sponsored by the City of Dixon, features organic fruits and vegetables, fresh-baked breads, hot

food vendors, live music and opportunities to meet local farmers. The association will

also present Railroad Days from 10 a.m. to 6 p.m. June 20 and 21 throughout downtown Dixon. The returning event will feature model railroad displays, craft vendors, Western reenactments and exhibits highlighting the city's railroad heritage and local history.

A new event, Downtown Dixon Cars & Q, is scheduled from 10 a.m. to 8 p.m. June 27 in downtown Dixon. Activities will include a classic car and truck show, a barbecue competition, street vendors, live music and promotions from

*Continued on page 2*

## Dixon's Action Team Cancels Grillin-n-Chillin



The City of Dixon is actively working with the Downtown Dixon Business Association and community partners to help support a similar community event on the same date. Photo courtesy of City of Dixon

City of Dixon News Release

**DIXON, CA (MPG)** - The City of Dixon understands how disappointing the cancellation of this year's Grillin-n-Chillin event is for many in our community. For years, this event has been an important tradition that brought people together and supported downtown businesses, local organizations and community causes.

We also want to acknowledge and thank the many volunteers and organizers who helped make Grillin-n-Chillin a success over the years. Their hard work, dedication and countless volunteer hours helped build an event that became a valued part of the Dixon community, and those efforts are sincerely appreciated.

The city also wants residents to know that we are actively working with the Downtown Dixon Business Association and community partners to help support a similar community event on the same date so families, businesses and visitors can still come together and enjoy a day in downtown Dixon.

Because there has been significant public discussion surrounding the cancellation, the city believes it is important to clarify some of the information that has been presented publicly.

Grillin-n-Chillin was not a city-run event. It was independently organized and hosted by a nonprofit organization. The city supported the event each year through financial contributions, staff time, public safety services, permitting assistance and other city resources to help make the event possible.

Following last year's event, both the City of Dixon and the event organizers were sued. As part of the normal requirements for events held on city property, Grillin-n-Chillin carried insurance to help cover and protect Dixon taxpayer dollars against litigation associated with such events.

Because the city was

*Continued on page 9*

## Randy Shafer Named Fire Chief

By Kendall Brown

**DIXON, CA (MPG)** - Firefighter Randy Shafer has been appointed fire chief of the Dixon Fire Department (DFD), marking a new chapter for a department where he has spent more than two decades serving in a variety of leadership and operational roles.

Shafer assumed the position earlier in 2026 after serving as acting fire chief for approximately one year. With more than 20 years in the department, he has advanced through the ranks, serving as firefighter-paramedic, engineer, fire captain, battalion chief and deputy fire chief.

His responsibilities throughout his career have included department operations, incident command and strategic planning efforts designed to strengthen emergency

*Continued on page 3*



Firefighter Randy Shafer has been appointed fire chief of the Dixon Fire Department (DFD), marking a new chapter for a department where he has spent more than two decades serving in a variety of leadership and operational roles. Photo courtesy of the City of Dixon



Scan our QR Code for a direct link to our online edition!

PRSRTD STD.  
U.S. POSTAGE  
PAID  
CARMICHAEL, CA  
PERMIT NO. 350  
OR CURRENT  
POSTAL CUSTOMER

# Kicking Off Summer

# Dixon News Briefs



Cornerstone Baptist Church is hosting the Third Annual Dixon Food Pantry Golf Tournament at 8:30 a.m. June 20. Registration costs \$125 per person and includes lunch and raffle prizes. Proceeds will benefit the church's food pantry program. Photo by Nicolas Brown

Continued from page 1 participating businesses.

For more information about DDBA events, visit [downtowndixonca.com/events](http://downtowndixonca.com/events) or email [dixondowntownba@yahoo.com](mailto:dixondowntownba@yahoo.com).

Community members can support local hunger relief efforts during the Third Annual Dixon Food Pantry Golf Tournament on June 20. Hosted by Cornerstone Baptist Church, the tournament begins at 8:30 a.m. at Cypress Lakes Golf Course, 5601 Meridian Road in Vacaville. Registration costs \$125 per person and includes lunch and raffle prizes. Proceeds will benefit the church's food pantry program.

For more information, visit Cornerstone Baptist Church on Facebook or call 707-678-5234.

Atkinson Self Storage will host a document shredding event from 10 a.m. to 1 p.m. June 13 at its facility, 1800 N. First St. The service costs \$10 per banker-sized box of papers and documents. Both cash and card payments will be accepted.

For more information, visit Atkinson Self Storage on Facebook or call 707-693-9200.

Creative residents can participate in "It's All About the Art Journal" at 6 p.m. June 12 at It's All About the Scrapbook, 1670 N. Lincoln St., Suite B. Led by instructor Mark Glimski, the workshop

is designed to encourage experimentation with mixed media, art journaling and paper crafts. Participants will have access to a variety of materials and techniques during the session. The cost is \$25.

For more information, visit [itsallaboutthescrapbook.com](http://itsallaboutthescrapbook.com) or call 707-676-5252.

The Dixon Library also has several programs planned for children, teens and families throughout the month.

A Teen Financial Literacy program presented by Patelco Credit Union is scheduled from 1 to 2 p.m. June 3 for youth aged 10 to 18. From 3 to 5 p.m. June 17, the library will host a Solano Pride Teen Game Night for the same age group.

A Water Bottle and Coffee Mug Swap will take place from noon to 3 p.m. June 20 and is open to all ages.

Recurring summer programs include Nintendo Switch Gamedays, held Tuesdays from 1 to 2:30 p.m. June 9 through July 21 for ages 10 to 18. Summer Smoothies for Teens will be offered Wednesdays from noon to 1 p.m. June 24 through July 22.

Several observances also take place during the month. Flag Day will be celebrated June 14, followed by Juneteenth on June 19. Father's Day will be observed June 21. June is also recognized nationally as Pride Month. ★



Dixon Community Theater (DCT) is hosting a theater class for students 7 to 17 years old beginning 6:15 p.m. June 9. Hosted at Dixon High School, 555 College Way, the class, led by DCT President Cheryl Sommers (left), will include four sessions of acting games, movement, voice work, improv and creative storytelling for \$35 per student. Photo by Nicolas Brown

By MPG Staff

## Dixon Teen Center Hiring

Dixon Teen Center is looking to hire a Teen Center Coordinator. The requirements of the position include excellent people skills, especially with teens, coordination experience, and availability every Friday and Saturday from 4 to 8 p.m.

For more information or to apply, visit Dixon Teen Center on Facebook or call either 707-695-2724 or 707-344-3544.

## Four Star Farm Horse Camp

Four Star Farm is offering a beginner to intermediate horseback riding camp beginning in mid-June. The farm, 7445 Pitt School Road, will have activities such as horseback riding, art projects and horsemanship for children aged 6 to 13 years old. Listed sessions are from 9 a.m. to 3 p.m. and include June 15 to 19, July 9 to 10 and August 3 to 7. Sessions cost \$695 per participant.

For more information, visit [fourstarfarm.com](http://fourstarfarm.com) or call 707-312-1119.

## Fort Sutter Antique Motorcycle Swap Meet

Fort Sutter Antique Motorcycle Association is hosting its annual swap meet and show from 9 a.m. to 5 p.m. both June 19 and 20. Held at the Dixon May Fair, 655 S. First St., the event will include competition, vendors and plenty of antique bikes for enthusiasts.

For more information, visit [fortsutteramca.org/upcoming-events/](http://fortsutteramca.org/upcoming-events/) or call 707-678-5529.

## Theme Park-Inspired Cookie Class

Every Baking Moment is hosting a Theme Park-Inspired Cookie Class from 6 to 8 p.m. June 5. Held at the shop, 143 N. First St., the event will teach attendees detailing, layering and decorating techniques to make treats shaped like pickles, pretzels, popcorn and more. Participation costs \$50 per person.

For more information, visit [everybakingmoment.com](http://everybakingmoment.com) or call 707-693-0112.

## Chamber Networking Lunch

The Dixon Chamber of Commerce is hosting a networking event from noon to 1:30 p.m. June 18. This free in-person event, held at Farmstead at Dixon, 350 Gateway Drive, allows local professionals to connect. Offering a diverse range of potential connections, attendees are encouraged to bring business cards. Lunch is provided.

For more information, visit [dixonchamber.org](http://dixonchamber.org) or call 707-678-2650.

## Dixon Family Services Fireworks Sale

Dixon Family Services will be selling fireworks from June 28 to July 4. The booth, held at Grocery Outlet, 2400 N. First St., will be selling TNT Fireworks to raise funds to support services offered by the nonprofit. Interested parties can also support the cause through volunteering to man the booth, but only those 18 and older are eligible.

For more information, visit Dixon Family Services on Facebook or call 707-678-0442.

## Bunco Night

Joystick Gaming Lounge will host its monthly Bunco Night from 6 to 8 p.m. June 25. Held at the lounge, 420 Gateway Dr., Suite C, the event includes prizes, with food and beverages available for purchase. The event costs \$20 per attendee. Proceeds from beer and wine sales will benefit Kiwanis Club of Dixon.

For more information, visit [joystick-dixon.com](http://joystick-dixon.com) or call 707-676-5697.

## Crafting Your Character

Dixon Community Theater (DCT) is hosting a theater class for students 7 to 17 years old beginning 6:15 p.m. June 9. Hosted at Dixon High School, 555 College Way, the class, led by DCT President Cheryl Sommers, will include four sessions of acting games, movement, voice work, improv and creative storytelling for \$35 per student. Classes are held on Tuesdays from 6:15 to 7:15 p.m. Additional dates include June 16, 23 and 30.

For more information, visit [dixoncommunitytheater.org](http://dixoncommunitytheater.org) or email [info@dixoncommunitytheater.org](mailto:info@dixoncommunitytheater.org).

## Primetime Barbershop Grand Re-opening

Primetime Barbershop, in partnership with the Dixon Chamber of Commerce, is hosting its grand re-opening from 1 to 2 p.m. June 27. Hosted at 145 E. A St., the event will celebrate the business's new location in downtown Dixon.

For more information, visit Dixon Chamber of Commerce on Facebook or call 707-678-2650.

## Read to a Dog

Dixon Library is hosting Read to a Dog from noon to 1 p.m. June 8. Hosted at the library, 230 N. First St., the activity provides children ages five to 12 with the opportunity to read aloud to certified therapy dogs. The program offers a relaxed, non-judgmental environment aimed at improving reading fluency and building positive reading experiences.

For more information, visit [solanolibrary.com](http://solanolibrary.com) or call 1-866-572-7587. ★

# Man Dies in Industrial Garbage Truck Incident



### City of Dixon News Release

**DIXON, CA (MPG)** - At approximately 8:53 a.m. May 29, the Dixon Police Department and Dixon Fire Department received a 911 call reporting a man trapped by a vehicle in the 100 block of Gateway Drive. Dixon Police and Dixon Fire responded and located an adult male pinned between an industrial garbage truck and a cinderblock wall.

Kristopher Payaslian, 50, of Vacaville, was pronounced deceased at the scene.

The California Division of Occupational Safety and Health (Cal/OSHA) responded and is conducting a separate investigation into the circumstances of the industrial accident. The Dixon Police Department is also conducting its own investigation into the cause of the incident.

The scene has been cleared and all roadways are open.

Anyone with information relevant to this incident is asked to contact the Dixon Police Department at 707-678-7070. ★



# LOCAL ARREST RECORDS

Find out what's happening in your local area at...

[INDEPENDENTVOICE.COM](http://INDEPENDENTVOICE.COM)

ARREST LOGS UPDATED DAILY

## Fisk's Cyclery

"Your family bike shop since 1976"

FULL SERVICE BIKE SHOP

Professional Affordable Repairs

**FAST SERVICE!**

Tuesday - Friday 9:30 - 6:00 PM • Saturday 9:30 - 3:00 PM

539 N. Adams St., Dixon • 707.678.4330

[fiskscyclery.com](http://fiskscyclery.com)

# Anderson PTO Named Nonprofit of the Year

By Kendall Brown

**DIXON, CA (MPG)** - Anderson Parent-Teacher Organization (PTO) was recognized as the 2025 Nonprofit of the Year during Celebrate Dixon March 14, honoring the organization's years of service and support for students, teachers and families at Anderson Elementary School.

The award recognizes the nonprofit's contributions to education, student enrichment and community engagement through fundraising, volunteer efforts and school programs.

For Anderson Elementary Teacher Lindsay Snyder, who has been a member of the organization for nine years, the announcement came as a surprise.

"I was completely shocked in the best way possible," said Snyder. "There were so many additional nonprofits that were nominated, and the fact that we got it was the best honor we could have won."

The recognition reflects the work of dozens of volunteers who help organize events, support fundraising efforts and provide resources for students and staff throughout the school year.

"It meant a lot to our PTO in particular," said Snyder. "Everything we do is for the students and staff at the end of the day, so to be recognized for what we have done is a huge honor and something we are very proud of. We want to continue doing good work and proving why we got this honor."

The PTO supports a variety of programs and activities at Anderson Elementary, including assemblies, field trips, classroom resources and schoolwide events. Snyder said the organization's commitment to student experiences and community involvement likely contributed to receiving the award.

"I think because we do so much for the students and try to be involved in activities for them to make school the best place for them," she said. "We try to be



The PTO supports a variety of programs and activities at Anderson Elementary, including assemblies, field trips, classroom resources and schoolwide events. Photo by Nicolas Brown

involved with the community as much as we can, too, so that played a big part in it."

Over the years, the organization has expanded its efforts to provide additional opportunities and resources for students and teachers.

"We just wanted to continue to grow and bring everything we can to our students, like assemblies, and fundraisers, and supplies," said Snyder. "We want to do everything we can to raise money for our teachers at the school, which supports the students and their growing needs."

Among the PTO's largest fundraising efforts are the annual Color Run and Fall Festival. Snyder said both events rely heavily on community support and partnerships with local businesses.

For the Color Run, the organization seeks donations from community members and businesses, with proceeds helping fund field trips and student assemblies. The Fall Festival features raffles supported by donated items from local businesses, with funds benefiting classrooms and educational



Anderson Parent-Teacher Organization (PTO) was recognized as the 2025 Nonprofit of the Year during Celebrate Dixon March 14, honoring the organization's years of service and support for students, teachers and families at Anderson Elementary School. Photo by Nicolas Brown

programs. "We work on experiences for the students and solidify community partnerships," said Snyder.

Snyder credited volunteers as the driving force behind the organization's success. Volunteers assist with tasks ranging from translation services and flyer distribution to social media management and event planning.

"The volunteers are the absolute reason we're successful," she said. "Every volunteer is a huge

factor as to why we are successful as we are."

One of the organization's early challenges was building volunteer participation. Snyder said the PTO began with only a small group of supporters, limiting what could be accomplished. Participation has since grown significantly.

"When I first started, it was a small group of us," said Snyder. "Now everyone wants to come, which is great."

As the current school year comes to a close, the PTO is already planning for next year's events, including the Color Run, Fall Festival and Book Fair.

Snyder expressed gratitude to the students, families, staff and community members who have supported the organization.

"Thank you for continuing to support Anderson PTO," she said. "We could not do it without the support of students, staff and community, and we look forward to continue hosting events for years to come."

She also encouraged other nonprofit organizations to remain committed to their missions.

"Don't give up, because everything you do has a positive impact on the students and the community and it's appreciated," said Snyder. "Continue to show up for the kids because they're our future."

For more information, visit Anderson Elementary PTO on Facebook or email [Andersonroadrunnerspto@gmail.com](mailto:Andersonroadrunnerspto@gmail.com). ★

## Senior Health Fair

Resources for The Golden Years

**INFORMATION & ENTERTAINMENT**  
FOR SENIORS, THEIR FAMILIES AND FRIENDS

**Saturday, June 20, 2026**  
10 am to 3 pm



**FREE Parking**

**FREE Admission**

**Wyndham Sacramento Hotel**  
Northeast 5321 Date Avenue  
Off of Highway 80 at Madison,  
Sacramento, CA 95841

- FREE EXHIBITS! • FREE ENTERTAINMENT!
- HEALTH SCREENINGS! • SAMPLES & PRIZES!

### Rock-n-Roll Concert and Classic Car Displays!



- Senior Care
- Medicare Options
- Home & Garden
- Sports & Fitness
- Anti-aging Programs
- Mental Health
- Veterans Information
- Chiropractors and Massage
- Natural Healing
- Health & Other Insurance
- Investment and Retirement
- And Much More!

**Great Entertainment & Live Music**

Hear old time rock n' roll, cruising songs, surfer songs. It's the music you grew up with!

sponsored by



[www.SeniorHealthFair.org](http://www.SeniorHealthFair.org) To Exhibit: 916.910.9499 or [info@recovery4all.org](mailto:info@recovery4all.org)

## Randy Shafer Named Fire Chief

*Continued from page 1*  
response capabilities and community safety. He has also played a role in improving communications, supporting department resilience and overseeing areas such as training, resource allocation, fleet management and facilities maintenance.

For Shafer, the promotion represents both a professional milestone and a personal honor.

"It's an opportunity to move our department into the future and leave the department better than I found it," said Shafer. "Over the last 20 years, we've made a lot of progress, and now it's my opportunity to take it to the next level."

He added that his long tenure in Dixon has created strong ties to the community.

"Personally, it's an honor to lead this department," said Shafer. "The community is close-knit. It's like a family to me."

Shafer's career in the fire service began while he was still in high school as a junior firefighter with the Vacaville Fire Protection District. After attending EMT school, he served as a reserve firefighter in Fairfield before being hired as a firefighter-paramedic. He later rose through the ranks at the Dixon Fire Department, eventually serving as acting fire chief from March 2025 until February 2026 before receiving the permanent appointment.

He credited previous department leaders with helping prepare him for greater responsibilities.

"Prior leadership was a



Among his immediate priorities as fire chief are beginning construction of Fire Station 82, filling staffing vacancies and helping develop a long-range master plan for the department. Photo by Nicolas Brown

good example and really prepared people for the next level of their career, as well as the constant challenge that comes with the leadership role," said Shafer.

Among his immediate priorities as fire chief are beginning construction of Fire Station 82, filling staffing vacancies and helping develop a long-range master plan for the department. "Being a part of the master plan for the next 20 years of DFD will lay the groundwork for what we need to be successful and provide the support we need to the city," he said.

Shafer said another goal is developing future leaders within the department and ensuring personnel are prepared for advancement opportunities.

Community engagement will also remain a focus during his tenure.

"Community engagement is really about telling our story to the community and hearing their needs from a public safety perspective," said Shafer.

As wildfire season approaches, the department

is conducting annual training and working to ensure personnel are fully prepared for emergency response needs throughout the region.

Shafer also plans to expand firefighter wellness initiatives, including strengthening peer support programs and promoting work-life balance for department personnel. He said fostering a culture where firefighters feel comfortable discussing mental health challenges is an important part of those efforts.

Looking ahead, Shafer said he is eager to continue serving the community in his new role.

"It is an honor to be appointed to the fire chief position," he said. "I look forward to working with city management, City Council and residents to support a better Dixon."

Under Shafer's leadership, the department will continue focusing on emergency preparedness, public safety and long-term planning to meet the needs of the growing community. ★

# CORRECTION

Correction: In the story “Seniors Take a Proud Walk,” Dixon High School’s graduation time is listed as 7 p.m. It is actually at 9 a.m. June 6. The gates will open early at 7 a.m. for those who need additional assistance. It will be open to the general public at 8 a.m.

# Food & Farm NEWS

## Farms Increasingly use Drones for Aerial Applications

Drone operators say they see an uptick in business as agricultural drone application technology improves, farmers become more comfortable with it and more products receive aerial labels. Drones have proven useful for aerial applications, especially for specialty crops. “Vegetable crops have probably adapted drones faster than any other crop,” said Briana Layfield, president and owner of Temecula-based Ag-Bee LLC. “When vegetable plants start growing, (growers) can’t get tractors in past a certain growth stage.” Last winter, her company treated vegetables in the Imperial, Coachella and Pajaro valleys. Other seasons, the company flies coastal vegetable fields from Ventura to Watsonville. Nicholas Steed, who operates Oakdale-based UAV Ag Solutions with brother Brandon, said they’ve also experienced increased producer interest. The company has used drones to treat walnuts, almonds, alfalfa and field corn.

## Former Dairy Vet Looks to Improve Welfare on Farms

Founded in 2022, Tennessee-based nonprofit Kinder Ground makes animal welfare improvement more accessible on farms by offering grants and expertise to farmers who are looking to learn more about animal welfare. “The idea is for farmers to come to us with ideas,” Jen Walker, chief animal welfare officer at Kinder Ground, told Ag Alert® in an interview. “We really like projects

that elevate welfare beyond those basics. Sometimes it’s seeing the simplest of opportunities. That’s where I think relationships are important. What we have found is if a farmer can have somebody go in on it with him or her, it’s much easier to take a risk.” A former dairy veterinarian, Walker said one new animal welfare technology she is excited about is cattle-vision goggles. “It’s a computer program that takes input from a camera and digests it, and puts it up in virtual reality goggles so that what you’re seeing is what we think cows would see,” she said.

## Committee Meets to Advise DWR on State Water Plan

An advisory committee to the California Department of Water Resources held its first meeting this month to begin work on the next update to the California Water Plan, the state’s long-range strategy for managing water resources across all sectors. The plan is updated every five years and guides statewide water policy, planning and investment priorities. The meeting came months after Gov. Gavin Newsom signed Senate Bill 72 in October 2025, launching a multiyear effort to modernize California’s water planning framework in response to intensifying droughts, floods and long-term water reliability challenges tied to climate change. SB 72 established an interim statewide planning target of 9 million acre-feet of additional water supply by 2040. The target is expected to play a central role in the development of the state’s 2028 and 2033 water plans. ★



# Riley Reviews

LIFETIME MOVIES TOUCH FAITH AND THRILLS; HOLOCAUST STORY ON PBS

## A Film and TV Review by Tim Riley

### LIFETIME MOVIES DURING JUNE

The Lifetime channel is versatile in its selection of original movies, and the month of June brings a range of new films from faith-based drama to psychological thrillers.

“Thou Shall Not Commit Adultery” takes an interesting turn with gospel artist Erica Campbell starring as Cassie Newton, a celebrated Christian feminist icon and bestselling author, finding her world turned upside as the result of a blackmail scheme.

Evidence of an extramarital affair causes Cassie to grapple with the consequences of her actions coming to light, which threaten her career, marriage, and the trust of devoted followers.

CJ Williams stars as Daniel, Cassie’s husband, whose steadfast love is put to the ultimate test, while the other man (Trai Byers) in the love triangle portends a toppling of a strong Christian woman’s carefully constructed life.

Jasmine Guy appears as world-famous empowerment speaker Anita Pierce, while former NBA champion Matt Barnes (with teams like the Lakers, Golden State Warriors, and Sacramento Kings, among others) makes his movie debut as Detective Wilson.

“Thou Shall Not Commit Adultery” leads to high stakes for Cassie to confront her own hypocrisy and make an impossible choice. Will she compromise her principles to protect her brand and the safety of her followers, or will she risk losing everything by exposing her own failings?

A twisted tale of love, jealousy, and obsession in the faith-based thriller “The Jealous Bride” finds Meg (Amber Stevens West) preparing for her wedding with Josh (Michael Xavier).

With the nuptials pending, the sudden return of Simone (Donna Benedicto), a woman from her fiancé Josh’s past, ignites a wave of jealousy she can’t contain. Consumed by doubt, Meg spirals into a perilous obsession that threatens to destroy her love, her faith, and her future.

Based on bestselling author Liv Constantine’s book “My Sister’s Daughter,” the Lifetime movie “Don’t Trust the Girls Upstairs” stars Grammy-nominated and BET Award-winning artist Remy Ma, along with Garfield Wilson, in a gripping psychological drama.

Remy Ma’s Ashley Preston is a woman forced to confront her past when her life begins to unravel. After the sudden death of her estranged sister, Ashley and her husband Elliot (Wilson) open their home to her orphaned teenage niece Serena (Aliyah Marc).

Hoping to offer a fresh start to Serena, Ashley is left questioning everything and everyone when a series of disturbing incidents begins to escalate. Is Serena acting out in grief? Or is Ashley’s own daughter Luna

(Sasha Rojen), whose troubled past still lingers, hiding something far more dangerous? As tensions mount and trust erodes, Ashley must uncover the truth before the threat inside her home turns deadly.

### “THE LAST TWINS”

#### Holocaust Documentary on PBS

The PBS documentary “The Last Twins,” narrated by actor Live Schrieber, chronicles the gripping portrait of an unsung hero who defied the Nazis and risked everything to protect some of the most vulnerable at Auschwitz.

Young twins sent to the infamous concentration camp were sometimes spared immediate death for the gruesome fate of being subjected to medical experiments by the evil Nazi doctor Josef Mengele.

During World War II, several German physicians conducted brutally painful and often deadly experiments on prisoners without their consent. Even before the war, twins were a major focus of genetic research under different circumstances.

The documentary is the story of Emo “Zvi” Spiegel, a fellow Jew who saw the plight of helpless young boys and shielded them from death and unimaginable harm. When liberation came, Spiegel led the boys across war-torn Europe on a harrowing journey towards their homes.

Through first-hand testimony and exclusive archival material, “The Last Twins” brings to life the voices of the boys who survived because of Spiegel’s defiance. His acts of humanity didn’t just save lives – they created a legacy.

Today, the children Spiegel protected have families of their own, with descendants who are researchers, advocates, lawyers, and musicians living all over the world.

According to co-director Perri Peltz, “Emo Spiegel’s story reminds us that even in the darkest places, there are people who choose to act with courage and compassion.”

“We are at a critical point in history – a moment when memories of the Holocaust are fading, and the resurgent tide of antisemitism and bigotry coursing through our world makes remembering more imperative than ever,” added co-director Matthew O’Neill.

The United States Holocaust Memorial Museum is an excellent resource for the history of Nazi medical experiments, noting that “From 1933 to 1945, Nazi Germany carried out a campaign to ‘cleanse’ German society of individuals viewed as biological threats to the nation’s ‘health.’”

That “The Nazis enlisted the help of physicians and medically trained geneticists, psychiatrists, and anthropologists to develop racial health policies” is beyond disturbing. The museum notes that the most infamous medical experiments were conducted by Dr. Mengele at Auschwitz. ★

# Ask DR. UNIVERSE

## What is a solar panel and how does it work?

- Jake, 8, Wisconsin

Dear Jake,

Right now, Washington state uses water through dams to make most of our electricity. But we’re also working hard on another kind of renewable energy: solar.

I asked my friend Allie Higginbotham about solar panels. She’s a scientist who works with the Energy Program at Washington State University.

She told me that a solar panel is a device that uses the sun to make electricity.

“A solar panel is made of smaller units called photovoltaic cells, or solar cells,” Higginbotham said. “They’re arranged in a grid on a solar panel—like you see on rooftops. A bunch of panels strung together is a photovoltaic array. Its job is to convert light into electricity.”

Each solar cell is about the size of a cell phone. But it’s super thin—like two sheets of paper stacked together. A solar panel contains many solar cells.

If you could zoom in on a solar cell, you’d see gobs of teeny, tiny silicon atoms—many septillions of them.

Those silicon atoms sandwich together in two layers in a solar cell. Each layer has little bits of other elements added to it. That helps create an electric field that pushes electrons in one direction.

If you look up silicon

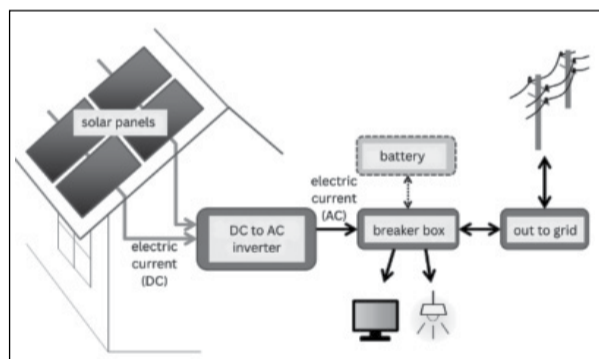

Electric current moves from the solar panel to the outlets in your home. The current starts as DC, where electrons mostly go in one direction through the wire. Then it’s converted into AC, where the electrons move back and forth very quickly. Courtesy photo

on a periodic table, you’ll see its atomic number is 14. That means a silicon atom has 14 protons. It usually has 14 electrons, too. They whizz around it like a cloud.

When the sun’s light hits a solar panel, the bits of light—called photons—bang into the silicon atoms. They knock some electrons loose. That leaves empty spots where the electrons used to be.

The solar cell’s electric field pushes the loose electrons up to the top. Then metal parts on the solar cell collect the electrons.

When electrons flow together in one direction, that’s an electric current.

The electric current moves out of the solar panel. It flows into copper wire. Then it travels off the roof and into a machine that changes the type of current from DC to AC. That makes it usable by the outlets in your home.

travels through more wire into your breaker box. Then, it’s sent out to your electrical outlets. You use that electricity to power your lights and devices.

Electricity always needs a complete path to flow. That complete path is called a circuit—because the electric current moves through a whole loop.

If it’s super sunny, your solar panel might make more electricity than you can use. Your system might save some in a big battery. It might push some into the shared electrical grid. Your neighbors can use it. The power company tracks how much electricity you shared. Then you can use electricity from the shared grid when you need it—like if it’s a very cloudy day.

When it comes to making electricity, solar panels really shine.

Sincerely,  
Dr. Universe

**MPG**  
**WE SUPPORT FIRST RESPONDERS**

**Dixon Independent Voice**  
Serving Dixon and Solano County since 1993

It is the intent of the *Dixon Independent Voice* to strive for an objective point of view in the reporting of news and events. It is understood that the opinions expressed on these pages are those of the authors and cartoonists and are not necessarily the opinions of the publisher or our contributors.

The *Dixon Independent Voice* is not responsible for unsolicited manuscripts or materials. The entire contents of the *Dixon Independent Voice* are copyrighted. Ownership of all advertising created and/or composed by the *Dixon Independent Voice* is with the publishing company and written permission to reproduce the same must be obtained from the publisher.

Subscriptions should be mailed to:  
*Dixon Independent Voice*  
100 N. Adams, Dixon, CA 95620

Subscription rate is \$52 per year within Dixon and Solano County. \$72 per year (Mail only).

Main Office Address: 2508 Garfield Ave., Suite A, Carmichael, CA 95608. Call 916-773-1111 for more information. The *Dixon Independent Voice* is published weekly on Friday.

We are proud members of these newspaper associations.

**MPG** **CIRCULATION VERIFICATION COUNCIL**

**Publisher, Paul V. Scholl**

*Dixon Independent Voice* is a member of **Messenger Publishing Group**

To submit your articles, information, announcements or letters to the editor, please email a Microsoft Word file to: [Publisher@mpg8.com](mailto:Publisher@mpg8.com).

**Be sure to place in the subject field “Attention to Publisher.” If you do not have email access, please call us at (916) 773-1111.**

**MPG**  
**WE SUPPORT FIRST RESPONDERS**

# SAFE Employees Run Third Annual Flag Collection Drive

**SAFE Credit Union  
News Release**

**SACRAMENTO REGION, CA (MPG)** - Coinciding with Memorial Day weekend and Flag Day in June, SAFE Credit Union employees are holding their third annual U.S. Flag collection drive through Tuesday, June 30.

The drive, run by SAFE's employee resource group VALOR (Veterans for Loved Ones Resource), provides designated drop-off bins at SAFE branches where SAFE members and the public can bring old and damaged U.S. flags for proper retirement. Last year, VALOR collected more than 500 flags.

"We are so excited to provide this service for the third year to ensure that people can have their flags that are ready for retirement honored in the right way," said VALOR member and SAFE Credit Union Chief Technology Officer Mike McCarthy, who served in the California Army National Guard.

This year, U.S. flags can be dropped off at any of SAFE's 18 branches in the Sacramento area and at SAFE's headquarters at 2295 Iron Point Road, Folsom.

After the flags are collected, VALOR and SAFE employees will gather at the credit union's



SAFE Credit Union employees and VALOR members Kimberley Ross of Rio Linda, Tony James of El Dorado Hills, Nicole Bowman of Sacramento County, Nicole Bauer of Auburn, Christopher Rhodes of Folsom, Karen Thorson of Roseville area, Sharon Millar of Rocklin, Cierra Herbert of Rancho Cordova, Louis Mariner of Penryn and Brian Bussell of Colfax. Photo courtesy of SAFE Credit Union

headquarters to properly fold each flag before giving them to the Veterans of Foreign Wars (VFW) Post 6604 in Folsom to arrange retirement ceremonies under the U.S. Flag Code.

"Providing a flag collection service helps ensure worn American flags are retired with

the dignity they deserve, while giving people an easy, respectful way to do the right thing," said SAFE Credit Union Deposits Operations Manager and VALOR member Karen Thorson, of the Roseville area. "Many want to, but don't know how or where to properly retire a flag."

Thorson, a Blue Star Mom whose son Trevor is a Navy hospital corpsman, adds that the flag collection drive shows how "SAFE and VALOR honor service personnel, veterans and their families."

"We want to help foster a culture of respect, gratitude and

lasting support for those who are currently serving and have served," Thorson said.

VALOR's Executive Sponsor SAFE Credit Union Vice President IT Operations Robert Paduano, of Lincoln, said SAFE's commitment to honoring veterans and their families harkens back to its beginnings as a credit union.

"We are proud to honor that history and future military generations in this way," said Paduano, who served for 12 years in the California Army National Guard.

SAFE's 86-year heritage stretches back to 1940, when it started as a credit union serving Army Air Corps personnel at what would later become McClellan Air Force Base in Sacramento, now home to McClellan Park.

While being a member of the credit union no longer requires military affiliation, today SAFE proudly continues to celebrate and support its many employees and members who are active military, National Guard and reservists, veterans and families of active and retired military. The credit union has also awarded several grants and scholarships to nonprofit organizations supporting veterans and their families. ★

# Metal Supermarkets Expands Trade School Scholarship Program

## Awards \$20,000 to Eight Students

By MPG Staff

**SACRAMENTO, CA (MPG)** - Metal Supermarkets is doubling its annual trade school scholarship program this year, awarding \$20,000 in scholarships to eight students across the United States and Canada as demand for skilled trades workers continues to rise across North America.

The company announced the expanded scholarship initiative as industries throughout face ongoing workforce shortages and widening skills gaps in the trades. According to industry projections, the United States will need more than 320,000 new welding professionals by 2029.

Metal Supermarkets said the scholarships are intended to support students pursuing careers in skilled trades fields that are critical to manufacturing, construction, infrastructure and other industries.

"The skilled trades don't just hold strong in an economic downturn, but they are among the rare sectors that continue to experience significant growth in an unpredictable job market," said Jill Quinn, executive leader of PeopleReady Skilled Trades.

The scholarship program will award



The scholarship program will award eight students with \$2,500 each, paid directly to their certified trade school. Courtesy photo

eight students with \$2,500 each, paid directly to their certified trade school. Six scholarships will be awarded to students in the United States and two to students in Canada.

Applications are open through June 30.

To qualify, applicants must be accepted to and attending a post-secondary trade school program beginning in 2026. Eligible applicants include citizens, permanent residents and resident aliens legally residing in the United States or

Canada who hold a high school diploma, GED or equivalent credential.

Applicants must submit transcripts, a resume, proof of enrollment or acceptance into a certified trade school and up to three letters of recommendation. Optional submissions include photos of completed trade-related work demonstrating skill in their chosen field.

Scholarship recipients will be selected by a committee made up of Metal Supermarkets corporate staff and franchisees from both the U.S. and Canada. Selections will be based on academic achievement, extracurricular involvement related to the skilled trades and financial need.

Winners will be notified no later than July 31.

Metal Supermarkets said scholarship entries are accepted exclusively through its online application process.

Employees of Metal Supermarkets, franchisees, franchisee staff and their immediate family members are not eligible to apply.

For more information and to apply visit [metalsupermarkets.com/trade-school-scholarship/](https://metalsupermarkets.com/trade-school-scholarship/). ★

# CDFW Releases Ocean Salmon Harvest Tracking Tools

**California Department of Fish and Wildlife  
News Release**

**SACRAMENTO REGION, CA (MPG)** - The California Department of Fish and Wildlife (CDFW) is pleased to announce the launch of new digital tools to track the recreational and commercial in-season harvests of ocean salmon.

The new tools, available at CDFW's Ocean Salmon Fishery Information page, will allow recreational anglers to easily track the number of salmon caught and number of salmon remaining under each regional harvest guideline. In-season management allows fishery managers to close salmon seasons early should harvest guidelines be reached.

With recreational and commercial ocean salmon fishing seasons underway, anglers may be interested in knowing how much catch has accrued, and when fisheries in each area will close.

"We're excited to give salmon anglers the data they need to better plan their fishing seasons while at the same time leveraging technology to support in-season management and sustainable fisheries," said CDFW Director Meghan Hertel.

Sport anglers can expect to see updates to the recreational catch tracker twice a month throughout the duration of the salmon season. Recreational catch estimates are calculated based on half-month sample periods, broken out into the first half and second half of each month. The recreational catch tracker will be updated following the conclusion of each sample period. Updates may become more frequent when total catch is approaching a harvest guideline. Any notices



Anglers are always advised to check for updated information when planning an ocean salmon fishing trip. Season dates, bag limits, possession rules and gear restrictions can be found on CDFW's Ocean Salmon Fishery Information page. Photo courtesy of the California Department of Fish and Wildlife

of fishery closures will be posted on the page when they are determined.

The 2026 recreational ocean salmon fishery opened in the Monterey area south of Pigeon Point (37°11' N. Latitude) to the U.S.-Mexico border on April 11. Opening day for the California Klamath Management Zone and Fort Bragg area (from the California/Oregon Border south to Point Arena, 38° 57.5' N. Latitude) is June 13, and the San Francisco (Point Arena to Pigeon Point) area will open June 27. Each fishing area is managed under a regional specific harvest guideline. Fishing will continue through scheduled open periods between June and August or until the harvest guideline is reached, whichever occurs first. Fishing will reopen in September for a portion of the San Francisco area and in the Monterey area under a separate fall harvest guideline.

Anglers are always advised to check for updated information when planning an ocean salmon fishing trip. Season dates, bag limits, possession rules and gear restrictions can be found on CDFW's Ocean Salmon Fishery Information page. Public notification of any in-season change to regulations is made through the National Marine Fisheries Service (NMFS) Ocean Salmon Regulations Hotline at (800) 662-9825 or the CDFW Ocean Salmon Regulations Hotline at (707) 576-3429.

Annual state regulations for ocean salmon automatically conform to federal regulations set by NMFS using the process described in Section 1.95(b)(2), Title 14, California Code of Regulations. Federal regulations for ocean salmon fisheries off California were published in the Federal Register (91 FR 29092) on May 19 and took effect on May 16. ★

# Thompson and Democratic Caucus Chair Aguilar Host Student Town Hall

Office of Mike Thompson  
News Release

DAVIS, CA (MPG) - On May 27, Rep. Mike Thompson (CA-04) and Democratic Caucus Chair Pete Aguilar (CA-33) hosted a town hall for students on campus at UC Davis. The town hall provided students with a chance to ask questions about the issues that mattered the most to them, including affordability and student loans.

“The burden of student debt is crushing our young people. Students shouldn’t have to choose between getting an education and being able to afford rent, groceries or a future,” said Thompson. “I recently introduced the Lowering Student Loans Act to address this directly by capping student loan interest rates at two percent. We must make it affordable to get an



On May 27, Rep. Mike Thompson (CA-04) (right) and Democratic Caucus Chair Pete Aguilar (CA-33) hosted a town hall for students on campus at UC Davis. Photo courtesy of Office of Mike Thompson

education and easier to pay off student loans.”

“Thank you to all the students that attended Wednesday’s event. Our country is facing

challenging times and one of the best remedies are rooms full of young people who are engaged, informed and are ready to hold their leaders accountable.”

Affordability Issues  
Thompson knows that Californians are paying \$1,900 more per year in higher prices because of the President’s trade

war, which is why he introduced H.R. 6900 the American Affordability Act. This act would reduce the tax burden on student loan forgiveness and expand education tax credits to cover more years of college and workforce training. It would also lower rent, cut energy bills, make childcare cheaper, make healthcare more accessible and put more money back into Americans’ wallets.

Student Loans  
Thompson has introduced H.R.7820, the “Lowering Student Loans Act,” which would cap student loan interest rates at two percent. He has also been a consistent opponent of the Trump Administration’s cut to research funding, which supports universities across the country, including UC Davis. Thompson will continue fighting to improve the lives of students in Davis and across the country. ★

## Local Classifieds Advertise in your local community newspaper Call 916-773-1111

**Classified Advertising**  
Sell Your Stuff!  
Reach 1000's of Readers Every Week!  
916-773-1111

**We Support Our Military**

**For Sale**  
V-8 (Cadillac Engine) in 1995 Oldsmobile Aurora. 64,000 original miles. Must take whole car. Transmission is no good. \$500 or best offer. Call 530-742-9144 and leave message. (TFN)  
**LEGAL ADS FOR SOLANO COUNTY?**  
916-773-1111

**Are You a Pro?**  
Get the word out!  
Advertise in the Classifieds  
Call 916-773-1111  
**GOT LOCAL NEWS?**  
Call (916) 773-1111

**Health/Wellness**  
XOSIALX – Get Social. Be EXCEPTIONAL. XILERATE is redefining energy for everyone. It provides an authentic, jitter-free boost that appeals to both regular energy drink users, and those who may have avoided them due to artificial ingredients or harsh effects. FREE TO JOIN. www.cander-son.xosialx.com (TFN)  
**MPG**

**Need Help?**  
**Hire A Pro!**  
Buy and Shop Local!

**Landscaping/Maintenance**  
RESIDENTIAL, COMMERCIAL, HANDYMAN, MANY FIELDS: Irrigation (manual or automatic) installation or repair; cement, mow strips, masonry (walls & columns), retaining walls; fence installation (wood, vinyl, chain-link, iron); plumbing; mowing, edging, clean-up, hauling; pruning (all kinds of fruit or shade trees); tree removal, rock, bark or sod. Call Andy 530-701-8098. (TFN)

# CALL A PROFESSIONAL

**GET TO KNOW GREINER!**  
New customers take **\$50 OFF** your first service  
Heating & A/C maintenance, repair & replacement  
Water heater repair & replacement  
Solar installation  
Home performance, efficiency & comfort  
**Call Us Today!**  
**(916) 545-1784**  
www.iTrustGreiner.com  
NP-0120 CA #365955

**CREST JEWELERS**  
Jewelry  
Watches  
Sales  
Repair  
WE BUY SCRAP GOLD!  
Family-owned with pride by the Macias family since 1967!  
1296 West Capitol Ave (at Safeway Center) • 371-6440

**ALL AMERICAN PRO CONSTRUCTION & RESTORATION**  
★ FAMILY-OWNED & OPERATED ★ VETERANS & SENIOR DISCOUNTS ★  
★ GREAT CRAFTSMANSHIP & CUSTOMER SERVICE ★  
**SPECIALIZING IN KITCHEN & BATH REMODELS, WATER DAMAGE, PLUS MUCH MORE.**  
**BIG OR SMALL, WE DO IT ALL.**  
**GIVE US A CALL. 916-504-0188**  
HTTPS://AAPC.BUILD  
CSLB# 1089369, Licensed, Bonded & Insured

**LYTLE CONSTRUCTION INC.**  
Award-Winning Design/Build Firm  
Serving Sacramento for more than 38 years  
Remodeling and Design  
Certified Kitchen & Bath Remodeler  
• Additions  
• Kitchens  
• Bathrooms  
• Custom Cabinetry  
**FREE Consultation**  
**916-422-6639**  
LIC# 480492 www.lytleconstruction.com

**PROFESSIONAL PET WASTE REMOVAL SERVICE**  
**Total clean SCOOP TEAM**  
HONEST SERVICE. FAIR PRICING. SPOTLESS RESULTS.  
916-250-2506  
WWW.TOTALCLEANSCOOPTeam.COM

**Bobby's Seven Day Barber Shop**  
**Open Everyday!**  
1040 West Capitol Ave Suite E (Behind Subway)  
West Sacramento, CA 95691  
**Bobby Luna**  
**(916) 371-4676**  
Next to City Hall  
Corner of West Capitol and Merkle

**S & Y Cleaning Services**  
Weekly • Bi-Weekly • Monthly • One Time  
Weekends • Move-Ins • Move-Outs  
Lots of References on Request  
Gift Certificates Available  
**(707) 689-6532**  
FREE ESTIMATES

**We live where you live**  
We understand your propane service needs.  
WE ARE  
**Pro-Gas**  
**ALLIED PROPANE**  
**(707) 678-8500**  
1700 N. First Street | Dixon  
RobL@alliedprogas.com

Please call for a free in-home estimate!  
**HOUSE OF FLOORS**  
QUALITY WITH FRIENDLY SERVICE  
Hardwood-Laminate-Luxury Vinyl-Carpet-Tile-& More  
1690 N. Lincoln Street • Dixon, CA 95620  
**(707) 676-5385**  
houseoffloors@att.net • www.houseoffloors.org

**Be a part of something important**  
**Local Writers Wanted**  
We are looking for local Freelance Writers to provide great coverage.  
**MPG** Call us today at 916-773-1111

**Pregnant? Worried? We Can Help!**  
All services are free & completely Confidential.  
Info on Pregnancy, Adoption & Abstinence  
Post-Abortion, Miscarriage & Stillbirth Counseling  
**707-449-8991**  
Alpha Pregnancy Resource Center  
138 S. Orchard St. Vacaville

**To ADVERTISE CALL 916.773.1111**

[www.IndependentVoice.com](http://www.IndependentVoice.com)

There are hundreds of **LOCAL EVENTS** Waiting to be discovered at [independentvoice.com/calendar](http://independentvoice.com/calendar)  
Theater, Concerts, Crafts, Fitness, Dining, Cultural Groups, Museums, Gatherings, Clubs, Festivals, Expos, Classes, Spiritual, Support Groups

**FOLLOW US** for Local News and much more!  
**Dixon Independent Voice**  
Facebook: @DIVMPG8

# COMICS & PUZZLES

**The Spats** by Jeff Pickering

**POPEYE** by Keith Pines

**Amber Waves** by Dave T. Phipps

**SLAM!** by Dave T. Phipps

**Out on a Limb** by Gary Kopervas

**HOCUS-FOCUS** BY HENRY BOLTONOFF

Find at least six differences in details between panels.

Differences: 1. Candle is taller. 2. Arm is resting on table. 3. Back of chair is different. 4. Dial on stove is moved. 5. Light is shorter. 6. Hair is different.

**TIGER** by Bud Blake

**GRIN THE BEAR IT** by Dave T. Phipps

**Just Like Cats & Dogs** by Dave T. Phipps

**CROSSWORD**

B	L	O	B	S		T	E	D		S	K	A	T		
A	E	S	O	P		W	E	I		S	P	I	R	E	
I	G	L	O	O		I	N	S		T	A	S	T	E	
L	O	O	K	I	N	G		C		U	R	T	S	Y	
			S	L	Y		L	O	P	E					
P	T	A			T	A	B	U		S	P	L	A	S	H
E	E	L	S			L	U	M	P		S	E	T	T	O
A	N	T	E			A	M	B	L	E		S	L	O	W
C	O	A	T	I		P	A	U	L		S	A	R	D	
E	R	R	A	N	T		G	M	A	N		S	K	Y	
					S	O	L	O		T	E	A			
	S	A	L	U	T	E		S	E	A	S	O	N	S	
F	I	N	A	L		A	T	E		R	I	V	A	L	
A	D	O	P	T		F	O	R		E	D	E	M	A	
D	E	N	S			S	P	A		R	E	N	E	W	

**STATEPOINT CROSSWORD • GREETINGS**

**CLUES**

**ACROSS**

- Shapeless masses
- RFK's brother
- German card game
- "The Wolf in Sheep's Clothing" author
- Ancient Chinese dynasty
- Top of a steeple
- Ice house
- Not out
- Gustatory sensation
- "What's cooking, good \_\_\_?"
- "Greeting aimed at a king
- Like a fox
- Easy run
- "Harper Valley

**DOWN**

- Off-limits
- Daryl Hannah/Tom Hanks movie
- Snaky swimmers
- Coal unit
- Vigorous fight
- Done before dealing
- Walk leisurely
- Like certain food trend
- Raccoon's South American cousin
- Dano or Rudd, e.g.
- Deep-red variety of chalcedony
- Straying, as in baseball
- FBI agent, slangily
- It's the limit?
- Alex Honnold's "Free
- Long Island iced

**34. \*Cowboy's greeting**  
**36. Bristle**  
**38. Little Jack Horner's treat**  
**42. Fill with happy spirit**  
**45. Injury's painful partner**  
**49. Toddler**  
**51. Closer**  
**54. Toronto Maple**  
**56. Comment to the audience**  
**57. Fries, e.g.**  
**58. At another time, to Romeo or Juliet**  
**59. Swimming lengths**  
**60. Doris Day's "Que**  
**61. Kitchen appliance**  
**62. Given at birth**  
**63. Cabbage dish**  
**64. Temporary craze**  
**66. \*\* \_\_\_ of the morning!"**

**Classified Advertising**

Sell Your Stuff!  
Reach 1000's of Readers Every Week!

**MPG**

916.773.1111

5	4	2	8	7	9	6	1	3
8	7	1	3	6	4	2	5	9
9	6	3	2	5	1	8	4	7
6	3	4	5	9	8	1	7	2
1	2	5	7	3	6	4	9	8
7	8	9	1	4	2	5	3	6
4	1	6	9	8	7	3	2	5
3	9	8	4	2	5	7	6	1
2	5	7	6	1	3	9	8	4

**Consumer Cellular**

Switch & Get \$25

Off First Month of New Service!  
USE PROMO CODE: GZ590

CALL CONSUMER CELLULAR 888-804-0913

**SUDOKU**

Call today and receive a **FREE SHOWER PACKAGE PLUS \$1600 OFF**

**SAFE-STEP WALK-IN TUB** 1-855-576-5653

	4		8					1
		1	3					5 9
	6			5				
6					8	1		2
1			7		6			8
7	9	1						6
				8				2
3	9				5	7		
	5				3			8

Fill in the blank squares in the grid, making sure that every row, column and 3-by-3 box includes all digits 1 through 9.

**WE SUPPORT FIRST RESPONDERS**

**MPG**

# Kings Korner

By V.G. Harris



## The Finals Are Here

If you've been watching what has turned out to be the coming out party for San Antonio's Victor Wembanyama, it would be easy to miss his impact in the final and deciding seventh game of the western division series. Wembanyama put up a solid 22 points, seven rebounds and two assists in what for him appeared to be a pedestrian performance. But stats alone won't tell this story which is one you don't want to miss.

When Oklahoma City ran the table last season with an overwhelming performance in the NBA playoffs and finals, they established themselves as by far the organization that had the best team. Many fans throughout the nation had to learn the names of the players as few were household names, but the chemistry on the court was something rarely seen.

At the center position the thunder reminded me of the 1975 Golden State Warriors when they came out of nowhere to win the championship with two no name centers that split time the entire series and were the consummate team players.

OKC took a chapter out of that book to produce seven-foot Chet Holgren and Isaiah Hartenstein who played as an ensemble that took the league by surprise and gave a lesson to one and all when it comes to true team basketball.

After enjoying one short year as NBA champions the Thunder have been dethroned, and of all things beaten at their own game.

Although the Spurs Victor Wembanyama will get the majority of the headlines and well deserved, it was the nearly perfect execution of team basketball that won the seventh game of this series. A total of seven players were in double digit scoring, and the Thunder were left wondering who beat us?

It was the team that beat you, and I have high hopes that the front office of the Sacramento Kings was watching.

Unable to capitalize on the stellar performance of MVP Shai-Gilgeous-Alexander who led the Thunder with 35 points, four rebounds and nine assists, OKC found out what they already knew. MVP or no, one player cannot do it by himself, and on their own court they had to watch as the San Antonio Spurs schooled the reigning

champions of how to play effective team basketball.

I admit to not seeing this coming. I was confident that the Thunder would unveil what got them there last year, but on this night, it was not to be. Inexplicably Chet Holgren played 33 minutes and added a paltry four points for the night and a total of four rebounds. His counterpart Isaiah Hartenstein played 21 minutes and had seven points and five rebounds for his efforts. While neither made a noticeable impact, Holgren may well have had the worst performance of his NBA career.

Everyone that plays this game has a worst ever performance, but few save it for the seventh game of a series that would have propelled them to the NBA finals.

Already pundits all beating the drum that Holgren is on the chopping block, and sadly for him, Chet Holgren may have played his last game for the OKC Thunder.

Time has a way of healing all wounds, and things may look better when a week or two passes, but great players answer the bell when it counts, and without question Holgren did not answer the bell.

Congratulations to San Antonio for their historic win, and even more on showing the world how to build a championship team, because that is quite likely what they are about to become.

The New York Knicks are saying wait a minute! How about us?

They would be right to say so, and I believe the finals may well surprise some people, but at this moment San Antonio looks like the odds-on favorite.

Pay attention Sacramento, because it was team basketball and not any one player that took out the thunder. Yes, Wembanyama is a force, but 22 points and seven rebounds is not an overwhelming stat, and it's what San Antonio did as a team that won the day.

Will we all be watching the finals as they get under way on Wednesday? I certainly will and it should be an entertaining series, but I'll be glued to my TV set on June 23 when the NBA trots out Adam Silver for this year's highly anticipated draft night.

*All the best Kings fans!* ★

## Gavin Newsom's Rosy Painting of California's Economy Leaves Out Its Darker Undertones



By Dan Walters,  
CALMatters.org

As Gavin Newsom makes his increasingly frequent appearances outside the state — seemingly preparing for a 2028 presidential campaign — one of his stock messages is that California's economy is soaring.

"We dominate in every category," Newsom bragged during a recent presentation to the Center for American Progress, a left-leaning think tank. "We are the center of the universe (and) America's coming attraction."

He cited the state's \$4-trillion-plus economic output that, were it a nation, would rank 4th or 5th largest in the world, and mentioned the ranks of Nobel Prize winners and vigorous venture capital investment in the state.

Moreover, he boasted, California has used that economic vigor to finance an array of social programs and services, such as universal health care, proving, he said, that such largesse can co-exist with capitalistic gains.

Subliminally, Newsom was pitching the notion that electing him as president could bring California-like prosperity and generosity to the nation as a whole. However, since Newsom is using the economy as a major talking point, it would be fair to provide key facts he fails to mention.

Yes, California has world-class economic output, but it

is due largely to a very narrow sector, Silicon Valley's high-tech industry, which has hugely benefited its entrepreneurs and capital investors.

However the industry is undergoing a shakeout due to the artificial intelligence phenomenon and it's shedding thousands of jobs, thus concentrating wealth even more.

Meanwhile the state's other world-famous sector, Southern California's movie and TV industry, is hurting badly as production migrates to other states and nations — so badly that the state is offering subsidies in an effort to slow the hemorrhage.

Ever since the COVID-19 pandemic, California's unemployment rate has routinely ranked among the nation's highest, with a million members of its labor force lacking jobs.

Beacon Economics, a major consulting firm that closely charts California's economic situation puts it this way: "On one hand, California's economy is in good health. While the official figures for the last quarter are still being tallied, the state's economic growth comfortably outpaced the national average of 2.5% in 2025, tracking toward an annual growth rate near 3%."

"At the same time, the job market is sagging. California now has the highest unemployment rate of all fifty states in the Union, stubbornly hovering at 5.5%, and its job market appears to be going in the wrong direction. The total number of jobs in California actually shrank by 0.6% since the beginning of this year, making it the 17th worst-performing state in the nation in terms of job creation."

One result of these contradictory data is one of the nation's highest levels of income disparity, as a recent report from the Public Policy Institute of California points out. Only eight other states have wider gaps.

"The gap between top and bottom incomes in California has increased substantially (by 57%) since 1980, when families at the top earned seven times more than those at the bottom," the PPIC report says, reflecting 72% income growth for those in the top tenth in income but 19% growth for those in the bottom tenth.

The Census Bureau's calculation of poverty that includes the state's staggering living costs puts California's rate at the highest, 17.7%, tied with Louisiana. A similar calculation by PPIC and the Stanford Center on Poverty and Inequality puts it at 16.9%, while another 17.9% of the population is "near-poor."

About 15 million Californians are poor enough to qualify for healthcare under the state's Medi-Cal program but, as Newsom failed to mention in his Center for American Progress presentation, his new budget reduces Medi-Cal eligibility for some Californians to shrink the state's chronic budget deficit, which he also didn't mention during his recitation of cherry-picked data.

*Dan Walters is one of the most decorated and widely syndicated columnists in California history, authoring a column four times a week that offers his view and analysis of the state's political, economic, social and demographic trends.* ★

## Social Security Matters

### I'm being Released from Incarceration. What Are My Social Security Options?



By Russell Gloor,  
AMAC Certified Social  
Security Advisor

**Dear Rusty:** In a previous column, you wrote about people who filed for Social Security late in life. I am currently incarcerated and will be filing for Social Security in the fall of 2029. I will be 74 years old in the first week of January 2029. Unless I read it wrong, could I be eligible to collect the previous 6 months? If this is so, how would that work? Would I get that all at once or incrementally? According to the chart we once got in the mail, I should be collecting the maximum amount. I've worked all of my life and never collected Social Security before. Also, my ex-wife remarried and has since passed away. Do I qualify for part of her Social Security? **Signed, "D" in Danbury**

**Dear "D" in Danbury:** I'm afraid you cannot receive Social Security benefits while you are incarcerated, even if you are eligible for them prior to your release. Thus, you cannot get retroactive Social Security benefits for any period you were still incarcerated. For clarity, although most who apply at a later age (e.g., in their 70s) do have the option to

claim retroactive benefits, you cannot get any SS benefits for any month you were still incarcerated. Further, you will not get credit for delaying your application for SS benefits while you are incarcerated (you won't earn Delayed Retirement Credits (DRCs) during your incarceration).

Assuming (from what you shared) that you expect to be released from incarceration in the fall of 2029, you can apply for your SS benefits to start upon your release. Be aware, however, that it usually takes several months for your application for SS benefits to be processed, and you can specify the month you wish your benefits start. Your benefit amount will be based upon your average monthly earnings for the 35 highest earning years over your lifetime. But you cannot get retroactive SS benefits for time prior to your release from incarceration. Since Social Security does not pay benefits for partial months, you can file for your SS benefits to start effective with the month following the month in which your incarceration ends. Be sure you have your official prison release documentation (parole or discharge papers) in hand when you apply for your Social Security benefits.

FYI, some correctional facilities have a "Prerelease Agreement" with Social Security, which may enable you to file for your SS benefits three to four months prior to your release from incarceration. Be sure to

check with your facility to see if they have such an agreement with Social Security and, if so, use it to apply for your benefits in advance of your release. This will facilitate your SS benefits starting more quickly upon your release.

You did not ask about healthcare coverage, but since you will be eligible for Social Security, you will also be eligible for Medicare upon your release. When you apply for your Social Security benefits, you can also apply for Medicare Part B (coverage for outpatient medical services), the premium for which will be deducted from your Social Security payment. FYI, Medicare Part A (coverage for inpatient hospitalization services) is free and automatic because you are also eligible for Social Security.

Finally, regarding survivor benefits from your ex-wife, you can only get a surviving ex-spouse benefit if you were married for more than 10 years and your own SS retirement amount is less than your ex-wife was receiving at her death. In other words, you can only get one SS benefit — either your own or your deceased ex-wife's amount, whichever is higher.

*This article is intended for information purposes only and does not represent legal or financial guidance. It presents the opinions and interpretations of the AMAC Foundation's staff, trained and accredited by the National Social Security Association (NSSA).* ★



The Democrats couldn't complete their term paper, but handed it in anyway because too many people were wondering what had become of it.

Under pressure, the DNC finally released its autopsy of the 2024 election, after rampant speculation about what it contained and why it hadn't yet been made public. Did it include references to Gaza or didn't it? Why or why not? What explosive revelations were being kept from us?

It turns out that the autopsy is a thoroughly unimpressive, unfinished document that, in the sheer incompetence in its drafting and handling, says more about the low state of the current Democratic Party than any of its analysis.

DNC Chairman Ken Martin maintains that he delayed so long because he didn't want to create a distraction by releasing a poorly done report, which sounds like a typical Washington excuse for hiding something. Except it wasn't. Once everyone saw the report, they realized Martin was right about the embarrassingly poor handling of his own autopsy.

At the start, the autopsy contains a disclaimer that "the DNC was not provided with the underlying sourcing, interviews or supporting data for many of the assertions contained herein and therefore cannot independently verify the claims presented."

Then, throughout the document, there are hostile

## An Autopsy as Malpractice

annotations casting doubt on its claims. And the report doesn't have a conclusion. The Democrats would have been better off going with ChatGPT.

That said, the report acknowledges that Democrats are out of touch and too dependent on the Republicans making poor candidate choices (something the GOP may be about to do again in its Texas Senate primary with the Trump-endorsed, scandal-plagued Attorney General Ken Paxton).

It notes how Trump's they/them ad hitting Kamala Harris on trans issues was devastating and unanswerable.

It recognizes that Harris didn't do enough to separate herself from Biden and make an affirmative case for herself, rather than relying on voters supposedly considering Trump unacceptable.

On the other hand, it fails to grapple with the issues of inflation and immigration (except to complain about Harris being given a role with some responsibility over the border). These were the two biggest substantive issues in the election, while the autopsy also whiffs on Biden's age and his catastrophically poor judgment in trying to run for reelection. (It also doesn't mention Gaza, bitterly disappointing the anti-Israel left.)

Yet, our expectations for such documents shouldn't be very high. What was the report going to say? That Democrats disgraced themselves by pretending that Biden was fit for a second term, and only shifted course when he got exposed in the first debate,

and then had no alternative but to turn to a charmless nonentity as a last-minute substitute?

The history of party retrospectives like this isn't good. Donald Trump won the presidency in 2016 by taking the recommendations of the GOP autopsy after its 2012 election defeat and often doing the opposite in substance and tone.

Democrats may be rudderless and increasingly extreme, but that doesn't mean they won't have a good election night this coming November. Usually, a party that has just lost the White House rises or falls in the midterms based on the incumbent president's job approval rating, rather than its own political creativity or inherent appeal.

As for retaking the White House, that typically depends on nominating someone who is charismatic and fresh, who has an unexpected approach to politics, and who develops a new coalition -- think Barack Obama in 2008, or Donald Trump in 2016.

TITLE: None of this comes about by having a political strategist talk to a bunch of people about the immediate past election and write a long report about it. Needless to say, Democrats should be grateful that the stakes of their autopsy are so low -- otherwise, they would have had to endeavor to actually finish it, and grapple with truths about the 2024 election conveniently passed over in the just-released document.

*Rich Lowry is editor of the National Review.*

*(c) 2026 by King Features Synd., Inc.* ★

# Invasive Glassy-Winged Sharpshooter Found on Plants Shipped to Solano Stores

## Solano County News Release

**SOLANO COUNTY, CA (MPG)** - The Solano County Agricultural Commissioner is urgently asking residents to take immediate action after invasive glassy-winged sharpshooters were detected on plant shipments delivered to Costco stores.

Residents who purchased grapevines or citrus plants from any Costco store since April 21 are strongly urged to follow the instructions below immediately to help prevent the spread of this destructive agricultural pest, including the following.

For grapevines: Place two garbage bags over plants and secure them tightly.

For citrus plants: Contact the Agriculture Department immediately to schedule an inspection.

Special instructions/contact: Do not return, transport, relocate, share or give away plants, and do not place plants in trash bins or compost containers. Contact the Solano County Agriculture Department at 707-784-1310 or email AGcomm48@SolanoCounty.gov to

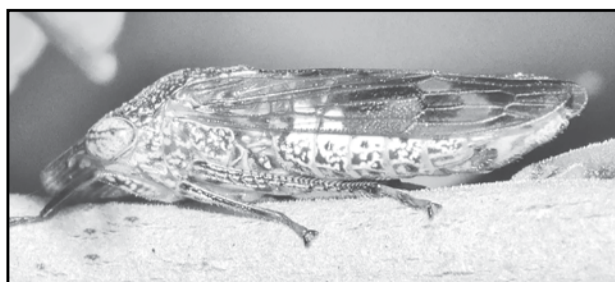

The Solano County Agricultural Commissioner is urgently asking residents to take immediate action after invasive glassy-winged sharpshooters were detected on plant shipments delivered to Costco stores. Photo courtesy of Solano County

schedule pickup of grapevines and/or inspection of citrus plants and receive guidance on preventing further spread of the glassy-winged sharpshooter

“Glassy-winged sharpshooters pose a serious and immediate threat to vineyards, agriculture and backyard plants throughout Solano County and surrounding regions,” said Ed King, Solano County Agricultural Commissioner. “These insects spread the bacterium that causes Pierce’s disease, which can kill grapevines and severely impact vineyards. Community cooperation is critical right now. If you recently purchased grapevines or citrus plants from

Costco, we are asking you to contact the Agriculture Department immediately so we can safely contain and eliminate this threat.”

In addition to threatening California agriculture, glassy-winged sharpshooters can damage a wide range of plants in residential landscapes. Since 2021, the Agriculture Department has worked successfully with residents in Vacaville’s Browns Valley neighborhood to eradicate localized infestations. However, recent detections in plant shipments delivered to Vacaville and Fairfield now threaten to reverse that progress and increase the risk of wider regional spread if immediate action is not taken. ★

# Dixon's Action Team Cancels Grillin-n-Chillin

Continued from page 1

named in the lawsuit, the city’s risk management legal counsel notified the event organizers that, under the event agreement, the insurance coverage and indemnification provisions for the event applied to the city’s defense costs related to the litigation. The city’s position has consistently been that the insurance policy purchased for the event should provide the coverage it was intended to provide.

At this time, the event’s insurance company has denied coverage for both the event organizers and the city. The city is actively pushing back against that denial and is demanding that the insurance company honor the policy and provide coverage for both the event organizers and the city in this litigation. To be clear, this is fundamentally an insurance coverage issue — not an effort by the city to seek money from the event organizers themselves. The lawsuit is currently being handled by the city’s own insurance

and outside risk management legal counsel, not the City Attorney’s office. The city continues to support the Grillin-n-Chillin event, and the city’s efforts in this matter should also benefit the event organizers as the case moves forward.

The city’s hope is that Grillin-n-Chillin will be able to return in the future and continue the tradition that so many residents, businesses, volunteers and visitors have enjoyed over the years.

We understand emotions surrounding this situation are strong, and we know many residents are saddened by the loss of a longtime community tradition. The city remains committed to supporting community events, local businesses and organizations that make Dixon special.

Our focus moving forward is bringing the community together, supporting downtown businesses and helping ensure residents can continue to enjoy safe and successful events in Dixon for years to come. ★

## LOCAL ARREST RECORDS

**INDEPENDENTVOICE.COM**

**Find out what's happening in your local area**

**Arrest Logs updated daily**

## LEGAL ADVERTISING

Dixon's Independent Voice Adjudicated For and By the County of Solano, Adjudication No. FCS030046 – November 24, 2008

Legal Advertising  
916-483-0946
2508 Garfield Ave. • Ste. A  
Carmichael, CA 95608

### FICTITIOUS BUSINESS NAME STATEMENTS

**FICTITIOUS BUSINESS NAME STATEMENT FILE NO. 2026000792**  
The following persons are doing business as: Indo Fiji Cash & Carry, 1322-1324 W Texas Street, Fairfield, CA 94533. Grocery Galaxy LLC, 1322-1324 W Texas Street, Fairfield, CA 94533.  
Date filed in Solano County: April 29, 2026. The Registrant commenced to transact business under the above business name on: April 28, 2026  
This Business is conducted by: A Limited Liability Company. NOTICE: In Accordance with subdivision (a) of section 17920 A Fictitious Name Statement generally expires at the end of five years from the date on which it was filed in the office of the county clerk, except as provided in subdivision (b) of section 17920, where it expires 40 days after any change in the facts set forth in the statement pursuant to section 17913 other than a change in the residence address of registered owner. A new fictitious Business name statement must be filed before the expiration April 28, 2031. The filing of this statement does not itself authorize the use in this state of a Fictitious Business Name in violation of the rights of another under federal, state, or common law (see section 14411 ET SEQ., business, and professions code.)  
Publish: May 15, 22, 29, June 5, 2026  
INDO 6-5-26

**FICTITIOUS BUSINESS NAME STATEMENT FILE NO. 2026000576**  
The following persons are doing business as: Your Unique House, 1501 Alamo Drive Apt 33, Vacaville, CA 95687. Luther McMillon, PO Box 915, Fairfield, CA 94533.  
Date filed in Solano County: March 27, 2026. The Registrant commenced to transact business under the above business name on: N/A  
This Business is conducted by: An Individual. NOTICE: In Accordance with subdivision (a) of section 17920 A Fictitious Name Statement generally expires at the end of five years from the date on which it was filed in the office of the county clerk, except as provided in subdivision (b) of section 17920, where it expires 40 days after any change in the facts set forth in the statement pursuant to section 17913 other than a change in the residence address of registered owner. A new fictitious Business name statement must be filed before the expiration March 26, 2031. The filing of this statement does not itself authorize the use in this state of a Fictitious Business Name in violation of the rights of another under federal, state, or common law (see section 14411 ET SEQ., business, and professions code.)  
Publish: May 15, 22, 29, June 5, 2026  
YOUR 6-5-26

**FICTITIOUS BUSINESS NAME STATEMENT FILE NO. 2026000859**  
The following persons are doing

business as: C and C Studio, 241 West A Street Unit A, Dixon, CA 95620. Cristina Ramos and Christian Vega Sanchez, 412 La Esperanza Drive, Dixon, CA 95620.  
Date filed in Solano County: May 11, 2026. The Registrant commenced to transact business under the above business name on: N/A  
This Business is conducted by: General Partnership. NOTICE: In Accordance with subdivision (a) of section 17920 A Fictitious Name Statement generally expires at the end of five years from the date on which it was filed in the office of the county clerk, except as provided in subdivision (b) of section 17920, where it expires 40 days after any change in the facts set forth in the statement pursuant to section 17913 other than a change in the residence address of registered owner. A new fictitious Business name statement must be filed before the expiration May 10, 2031. The filing of this statement does not itself authorize the use in this state of a Fictitious Business Name in violation of the rights of another under federal, state, or common law (see section 14411 ET SEQ., business, and professions code.)  
Publish: May 29, June 5, 12, 19, 2026  
STUDIO 6-19-26

**FICTITIOUS BUSINESS NAME STATEMENT FILE NO. 2026000910**  
The following persons are doing business as: Route 88 Fab Shop, 529 North Adams Unit B, Dixon, CA 95620. Adrian Olivares Frausto, 529 North Adams Unit B, Dixon, CA 95620.  
Date filed in Solano County: May 20, 2026. The Registrant commenced to transact business under the above business name on: N/A  
This Business is conducted by: An Individual. NOTICE: In Accordance with subdivision (a) of section 17920 A Fictitious Name Statement generally expires at the end of five years from the date on which it was filed in the office of the county clerk, except as provided in subdivision (b) of section 17920, where it expires 40 days after any change in the facts set forth in the statement pursuant to section 17913 other than a change in the residence address of registered owner. A new fictitious Business name statement must be filed before the expiration May 19, 2031. The filing of this statement does not itself authorize the use in this state of a Fictitious Business Name in violation of the rights of another under federal, state, or common law (see section 14411 ET SEQ., business, and professions code.)  
Publish: May 29, June 5, 12, 19, 2026  
ROUTE 6-19-26

**FICTITIOUS BUSINESS NAME STATEMENT FILE NO. 2026000924**  
The following persons are doing business as: Northern Star Landscaping, 266 Sungate Court, Vacaville, CA 95688. Jose Brisenno Sosa, 266 Sungate Court, Vacaville, CA 95688.

Date filed in Solano County: May 21, 2026. The Registrant commenced to transact business under the above business name on: January 2, 2017  
This Business is conducted by: General Partnership. NOTICE: In Accordance with subdivision (a) of section 17920 A Fictitious Name Statement generally expires at the end of five years from the date on which it was filed in the office of the county clerk, except as provided in subdivision (b) of section 17920, where it expires 40 days after any change in the facts set forth in the statement pursuant to section 17913 other than a change in the residence address of registered owner. A new fictitious Business name statement must be filed before the expiration May 20, 2031. The filing of this statement does not itself authorize the use in this state of a Fictitious Business Name in violation of the rights of another under federal, state, or common law (see section 14411 ET SEQ., business, and professions code.)  
Publish: May 29, June 5, 12, 19, 2026  
NORTHERN 6-19-26

**FICTITIOUS BUSINESS NAME STATEMENT FILE NO. 2026000790**  
The following persons are doing business as: True Reflex It, 3069 Alamo Drive #1049, Vacaville, CA 95687. Jordan Bruckopoulos, 3069 Alamo Drive #1049, Vacaville, CA 95687.  
Date filed in Solano County: April 29, 2026. The Registrant commenced to transact business under the above business name on: N/A  
This Business is conducted by: An Individual. NOTICE: In Accordance with subdivision (a) of section 17920 A Fictitious Name Statement generally expires at the end of five years from the date on which it was filed in the office of the county clerk, except as provided in subdivision (b) of section 17920, where it expires 40 days after any change in the facts set forth in the statement pursuant to section 17913 other than a change in the residence address of registered owner. A new fictitious Business name statement must be filed before the expiration April 28, 2031. The filing of this statement does not itself authorize the use in this state of a Fictitious Business Name in violation of the rights of another under federal, state, or common law (see section 14411 ET SEQ., business, and professions code.)  
Publish: May 29, June 5, 12, 19, 2026  
TRUE 6-19-26

**FICTITIOUS BUSINESS NAME STATEMENT FILE NO. 2026000742**  
The following persons are doing business as: Food Tree Field, 4870 McCune Road, Winters, CA 95694. Bamirni Lee, 4870 McCune Road Winters, CA 95694.  
Date filed in Solano County: April 22, 2026. The Registrant commenced to transact business under the above business name on: January 1, 2022  
This Business is conducted

by: An Individual. NOTICE: In Accordance with subdivision (a) of section 17920 A Fictitious Name Statement generally expires at the end of five years from the date on which it was filed in the office of the county clerk, except as provided in subdivision (b) of section 17920, where it expires 40 days after any change in the facts set forth in the statement pursuant to section 17913 other than a change in the residence address of registered owner. A new fictitious Business name statement must be filed before the expiration April 21, 2031. The filing of this statement does not itself authorize the use in this state of a Fictitious Business Name in violation of the rights of another under federal, state, or common law (see section 14411 ET SEQ., business, and professions code.)  
Publish: May 29, June 5, 12, 19, 2026  
FOOD 6-19-26

**FICTITIOUS BUSINESS NAME STATEMENT FILE NO. 2026000961**  
The following persons are doing business as: Just Work Training, 2404 Lake Club Drive, Fairfield, CA 94533. Mentally Strong LLC, 2404 Lake Club Drive, Fairfield, CA 94533.  
Date filed in Solano County: May 28, 2026. The Registrant commenced to transact business under the above business name on: N/A  
This Business is conducted by: A Limited Liability Company. NOTICE: In Accordance with subdivision (a) of section 17920 A Fictitious Name Statement generally expires at the end of five years from the date on which it was filed in the office of the county clerk, except as provided in subdivision (b) of section 17920, where it expires 40 days after any change in the facts set forth in the statement pursuant to section 17913 other than a change in the residence address of registered owner. A new fictitious Business name statement must be filed before the expiration May 27, 2031. The filing of this statement does not itself authorize the use in this state of a Fictitious Business Name in violation of the rights of another under federal, state, or common law (see section 14411 ET SEQ., business, and professions code.)  
Publish: June 5, 12, 19, 26, 2026  
JUST 6-26-26

**FICTITIOUS BUSINESS NAME STATEMENT FILE NO. 2026000767**  
The following persons are doing business as: Just Work Fitness, 2404 Lake Club Drive, Fairfield, CA 94534. Melina Armstead, 2404 Lake Club Drive, Fairfield, CA 94534.  
Date filed in Solano County: April 27, 2026. The Registrant commenced to transact business under the above business name on: N/A  
This Business is conducted by: A Limited Liability Company. NOTICE: In Accordance with subdivision (a) of section 17920 A Fictitious Name Statement generally expires at the end of five years from the date on which it was filed in the office of the county clerk, except as provided in subdivision (b) of section 17920, where it expires 40 days after any change in the facts set forth in the statement pursuant to section 17913 other than a change in the residence address of registered owner. A new fictitious Business name statement must be filed before the expiration April 26, 2031. The filing of this statement does not itself authorize the use in this state of a Fictitious Business Name in violation of the rights of another

under federal, state, or common law (see section 14411 ET SEQ., business, and professions code.)  
Publish: June 5, 12, 19, 26, 2026  
WORK 6-26-26

**FICTITIOUS BUSINESS NAME STATEMENT FILE NO. 2026000903**  
The following persons are doing business as: Turboride, 1350 Travis Boulevard, Fairfield, CA 94533. Sergio Cardenas-Mata, 11630 Arroyo Avenue, Hesperia, CA 92345.  
Date filed in Solano County: May 18, 2026. The Registrant commenced to transact business under the above business name on: N/A  
This Business is conducted by: An Individual. NOTICE: In Accordance with subdivision (a) of section 17920 A Fictitious Name Statement generally expires at the end of five years from the date on which it was filed in the office of the county clerk, except as provided in subdivision (b) of section 17920, where it expires 40 days after any change in the facts set forth in the statement pursuant to section 17913 other than a change in the residence address of registered owner. A new fictitious Business name statement must be filed before the expiration May 17, 2031. The filing of this statement does not itself authorize the use in this state of a Fictitious Business Name in violation of the rights of another under federal, state, or common law (see section 14411 ET SEQ., business, and professions code.)  
Publish: June 5, 12, 19, 26, 2026  
TURBORIDE 6-26-26

### ORDER TO SHOW FOR CHANGE OF NAME

**SUPERIOR COURT OF CALIFORNIA COUNTY OF SOLANO ORDER TO SHOW CAUSE CHANGE OF NAME CASE #CU26-04307**  
Ching-Dao Kong, filed a petition with this court for a decree changing names as follows: Ching-Dao Kong to Daniel Ching-Dao Kong. THE COURT ORDERS that all persons interested in this matter shall appear before this court at the hearing indicated below to show cause, if any, why the petition for change of name should not be granted. Any person objecting to the name changes described above must file written objection that includes the reasons for the objection at least two court days before the matter is scheduled to be heard and must appear at the hearing to show why the petition should not be granted. If no written objection is timely filed, the court may grant the petition without a hearing. July 8, 2026, 9:00 a.m. Department 3, Room 301, Hall of Justice, 600 Union Avenue, Fairfield, CA 94533  
Judge of the Superior Court: Christine A. Carringer  
Dated: May 13, 2026  
Publish: June 5, 12, 19, 26, 2026  
KONG 6-26-26

### NOTICE OF PETITION TO ADMINISTER ESTATE

**NOTICE OF PETITION TO ADMINISTER ESTATE OF DWIGHT L. JACKSON CASE NO. PR26-00302**  
To all heirs, beneficiaries, creditors, and contingent creditors of and persons who may be otherwise interested in the will or estate, or both, of Dwight L. Jackson. A Petition for Probate has been filed by Marlene Jackson, in the Superior Court of California, County of Solano, requesting Marlene Jackson be appointed

as personal representative(s) to administer the estate of the decedent.

The petition requests the decedent’s will and codicils, if any, be admitted to probate. The will and any codicils are available for examination in the file kept by the court.

The petition requests authority to administer the estate under the Independent Administration of Estates Act. (This authority will allow the executor to take many actions without obtaining court approval. Before taking certain very important actions, however, the executor will be required to give notice to interested persons unless they have waived notice or have consented to the proposed action.) The independent administration authority will be granted unless an interested person files an objection to the petition and shows good cause why the court should not grant the authority.

A hearing on the petition will be held in this court as follows: June 24, 2026, 9:30 a.m. in Dept 22; Superior Court of California, County of Solano, 600 Union Street, Fairfield, CA 94533.

IF YOU OBJECT to the granting of the petition, you should appear at the hearing and state your objections or file written objections with the court before the hearing. Your appearance may be in person or by your attorney.

IF YOU ARE A CREDITOR or a contingent creditor of the deceased, you must file your claim with the court and mail a copy to the personal representative appointed by the court within the later of either (1) four months from the date of first issuance of letters to a general personal representative, as defined in section 58(b) of the California Probate Code, or (2) 60 days from the date of mailing or personal delivery to you of a notice under section 9052 of the California Probate Code. Other California statutes and legal authority may affect your rights as a creditor. You may want to consult with an attorney knowledgeable in California law.

YOU MAY EXAMINE the file kept by the court. If you are interested in the estate, you may file with the court a Request for Special Notice (form DE-154) of the filing of an inventory and appraisal of estate assets or of any petition or account as provided in Probate Code section 1250. A Request for Special Notice form is available from the court clerk. The name, address and telephone number of the Attorney for Petitioner is: Jerilyn Paik, ESQ., Law Offices of Jerilyn Paik, 555 University Avenue, Suite 235, Sacramento, CA 95825; 916-568-1222  
Publish: May 29, June 5, 12, 2026  
JACKSON 6-12-26

**LEGAL ADS FOR SOLANO COUNTY?**

**We Can Do That!**

Call to place your legal advertising  
**916-773-1111**

### LIEN SALE AUCTION

Notice is hereby given that the undersigned will conduct a Lien Sale Auction on JUNE 29TH, 2026, at 10:00 AM. This is authorized by Division 8, Chapter 10 of the California Business and Professions Code. CASH ONLY. All items must be removed from the property immediately after sale.

DIXON SELF STORAGE 1410 REGENCY PKWY  
DIXON, CA 95620-4500

UNIT A064 - FALLON THOMAS - holiday decor, plastic bins with shoes, flat screen tv, floor fan, hats, side table, suitcase, bedding, clothes, misc. boxes and bins.

Dixon Independent Voice 6-5, 6-12-2026

# Sixty Years Later, His Scientific Dream Came True

## UC Davis News Release

DAVIS, CA (MPG) - More than 60 years ago, a teenage butterfly researcher in Philadelphia conceived a genomics research project involving the genus *Colias*, the sulfur butterfly. It never came to fruition because DNA genomics had not yet been invented.

Fast forward to today and the research project that the teen envisioned now appears in a newly published paper, "Temporal Dynamics of Color Polymorphism and Hybridization in *Colias* butterflies," in "Evolution," the international journal of organic evolution. That boy, now 80, is UC Davis Distinguished Professor Emeritus Art Shapiro.

"I never thought I'd see this in my lifetime," he said.

The work was mostly done in the lab of Shapiro's former doctoral student, Matthew Forister, the Trevor J. McMinn Endowed Research Professor in Biology, University of Nevada, Reno.

The nine-author team includes Shapiro.

"As is traditional in such cases, I am listed as the last author, the éminence grise position," he said. "And I did live to see my high-school dream realized. How many researchers can make that claim?"

"The research contributes to our understanding of an evolutionary phenomenon - introgressive hybridization - that at least superficially seems to defy theoretical expectations," said Shapiro. "It's gratifying to get far enough below the surface as to be able to see what is really going on, and that's what motivates basic research, after all. We are curious by nature - like cats."

It all came about when Shapiro, as a high school student fascinated with butterflies, corresponded with Charles Remington of Yale, then the foremost butterfly researcher in the United States.

"He guided me into the *Colias* system, which had already been studied by John Gerould of Dartmouth College, New Hampshire and William Hovanitz of California (who became a biology professor at California State University at Los Angeles). I did genetic research that propelled me to victory in the Delaware Valley and national science fairs and to a Westinghouse Science Talent Search full scholarship that enabled me to go to the University of Pennsylvania for my bachelor's degree in biology (1966), a life-changing experience."

Shapiro went on to receive his doctorate in entomology in 1970 from Cornell University. UC Davis successfully recruited him to its faculty in 1971.

Shapiro credits two books that he read as a teenager as sparking his *Colias* project: Julian Huxley's "Evolution: The Modern Synthesis" and Ernst Mayr's landmark book, "Animal Species and Evolution," which proposed that new species arise when populations become geographically or reproductively isolated, leading to the accumulation of different traits.

"All of this led me to design the definitive study I wanted to do on *Colias*," said Shapiro. "But I couldn't do it. In



A male orange sulfur butterfly, *Colias eurytheme*, in the UC Davis Bee Haven. Photo by Kathy Keatley Garvey



UC Davis Distinguished Professor Emeritus Art Shapiro. Photo by Kathy Keatley Garvey

fact, no one could do it because DNA genomics had not yet been invented - because there were no tools to do it! So, although I kept up my interest in *Colias* throughout my career and several of my students worked on it, the study hung fire until we had the tools to do it."

"I had been collecting samples over decades in full faith that it would be done - I could only hope, in my lifetime," he said.

Shapiro praised Remington (1922-2007) for "turning me on to the problem by providing me with photocopies of the *Colias* papers by John Gerould at Dartmouth and William Hovanitz of Southern California."

"The basic problem," explained Shapiro, "dealt with the phenotypes, the orange and yellow eastern sulphurs *Colias eurytheme* and philodice. In the West, philodice was replaced by an entity called eriphyle. It was hybridized everywhere it co-occurred. *Eurytheme* spread northward in response to the planting of a preferred host plant, alfalfa."

"But although apparent hybrids occurred at high frequencies, the species refused to merge - they remained distinct! I knew from the books that this was a problem that needed a solution; it went against theoretical expectations. I wanted to solve it. To do so would require actual quantitative knowledge of the amount of gene flow - introgressive hybridization - going on and the degree of randomness

vs. selectivity in mating. Thus, was the project conceived."

"I began by doing breeding to work out the Mendelian genetics of wing color. That was the project that gained me entry to the elite science fair circuit and then to Westinghouse Science Talent Search, which ultimately paid for my education at Penn."

He drew inspiration from Penn genetics professor Conway Zirkle "but mainly at Penn, I developed a serious interest in community and population ecology."

Shapiro has studied other North American *Colias* "but only superficially, and also with South American ones, mainly the Argentine *Colias lesbia* and the Chilean *C. vauthierii*, and green *Colias* from the high Andes in both northern Argentina and Peru."

His interest in *Colias* never waned. In fact, his very first publication addressed *Colias* seasonality (phenology) in Pennsylvania. Decades later, he published the first description of the early stages of one of the green Peruvian-Andean *Colias*.

"So, my interest was always there," said Shapiro. "Now that molecular genomics is a reality, the way was open to actually do what I had wanted to do in high school."

He teamed with Forister and his crew "who had the facilities to do such work and we did it."

"It was a bit late for me as an old goat to get into

the molecular-genomics business!" he added.

He's been asked: "Why didn't you do your dissertation on *Colias*?"

"As a college senior, I corresponded with Paul Ehrlich at Stanford about it - he was by then the leading American butterfly guy. We discussed it in some detail, but it was evident that there still was not - and would not be in the foreseeable future - a way to really get at the problem. One needed molecular genomics! I went to Cornell and

worked on the genetics of insect-host plant relationships instead. And never regretted it."

Shapiro pointed out that the only *Colias* in the Central Valley is *eurytheme*. *Eriphyle* occurs only on the east slope of the Sierra and in the Great Basin and Rockies.

Internationally renowned for his long-term data research, Shapiro has monitored the butterfly populations in central and northern California, encompassing some 115 species, since 1972. His

work, known as the largest butterfly monitoring data set in North America and one of the largest in the world, runs parallel to Interstate 80, with 10 sites distributed from the inner Coast Range, across the Sacramento Valley and the Sierra Nevada, to the western edge of the Great Basin. His sites span a wide range of climates and vegetations, from sea level to treeline at 9000 feet. His research appears on his website, "Art's Butterfly World," at <https://butterfly.ucdavis.edu/>. ★

## LOCAL NEWS

HAS NEVER BEEN SO IMPORTANT!  
**SUBSCRIBE NOW!**



ONLY  
**\$52\***  
PER YEAR

RECEIVE DIXON INDEPENDENT VOICE  
EVERY WEEK AT YOUR HOME OR BUSINESS!

**YES! START MY SUBSCRIPTION NOW!**

FULL NAME

STREET

CITY

ZIP

PHONE

EMAIL ADDRESS

MAIL YOUR PAYMENT TO GET STARTED IMMEDIATELY:



Office address:

P.O. Box 1106, Dixon, CA 95620

Dixon Independent Voice is published weekly on Friday.

\*Subscription rate valid only within Solano County



**DON'T WAIT! CALL NOW! 916-773-1111**